

Bio 10

Scanjet tank cleaning equipment



KEY FEATURES

Bio 10 is an advanced tank cleaning machine specially developed for:

- Food & Dairy
- Pharmaceutical
- Chemical Processing
- Transportation
- Beverage

Where

- Self-washing required
- Low fluid consumption
- Hygienic design

The Bio 10 rotary jet head is a hygienic tank cleaning machine that provides 360deg coverage within a given tank or process vessel. The Bio 10 is self powered by the flow of the fluid through the inlet cone of the machine. An increase in pressure and flow will correspondingly increase the length of the jet and impact upon the tank or vessel surfaces. The Bio 10 employs exclusive self-washing features that allows itself to be completely covered and has been certified in rinse validation protocols such a riboflavin rinse validation and yogurt washing trials.

Quality Standards

The Bio 10 is produced in accordance to stringent quality standards and meets or exceeds ISO 9001 International Quality Standards as well as conforming to the cGMP as detailed by the United States FDA (Food and Drug Administration and EHEDG (European Hygienic Equipment Design Group).

Typical Cleaning Methods:

- Fixed Installed CIP Systems
- Multi-Tank Solution Recovery
- Single Use/Single Pass
- Single Use/Recirculatory

Typical application for the Bio 10:

- Process vessels and reactors
- Storage tanks
- Transportations tanks
- Fermenters
- Yeast propagation



Technical performance

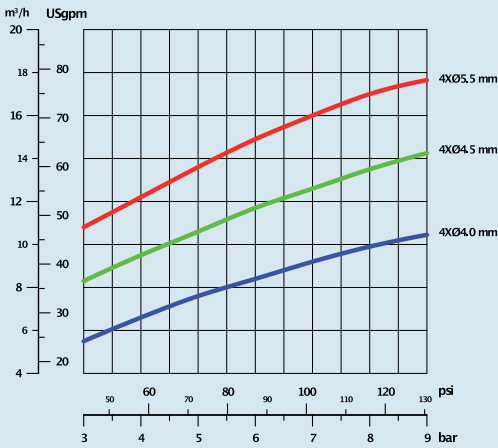

Pressure/Flow

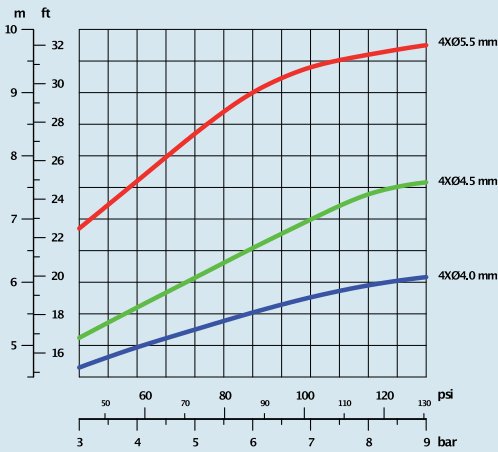

Jet length

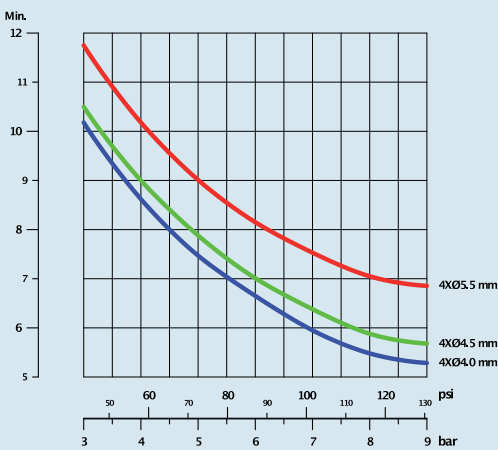

Pattern time

Dimensions

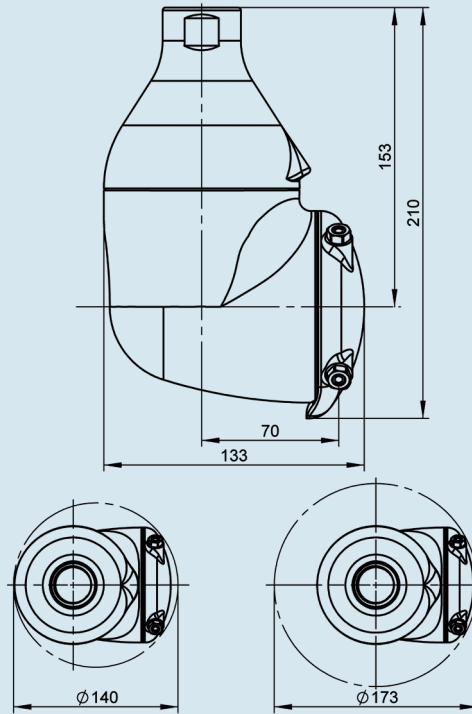

Specifications

Flow	5-16 m ³ /h
Inlet pressure	3-10 bar
Max pressure	12 bar
Recommended pressure	6 bar
Max temperature	95°C
Max ambient temperature	140°C
Weight	5,1 kg
Connections standards	See model # table
Material	AISI 316, PTFE, PEEK
Lubrication	Cleaning media

Standard product program model # table

Model #	Nozzles	Connection
B 10-4x4.0-104	4x4.0 mm	1" NPT (F)
B 10-4x4.5-104	4x4.5 mm	
B 10-4x5.5-104	4x5.5 mm	1" BSP (F)
B 10-4x4.0-064	4x4.0 mm	
B 10-4x4.5-064	4x4.5 mm	1" Clip-On
B 10-4x5.5-064	4x5.5 mm	
B 10-4x4.0-824	4x4.0 mm	1" Weld-On
B 10-4x4.5-824	4x4.5 mm	
B 10-4x5.5-824	4x5.5 mm	1.5" Weld-On
B 10-4x4.0-844	4x4.0 mm	
B 10-4x4.5-844	4x4.5 mm	1.5" Weld-On
B 10-4x5.5-844	4x5.5 mm	
B 10-4x4.0-846	4x4.0 mm	
B 10-4x4.5-846	4x4.5 mm	
B 10-4x5.5-846	4x5.5 mm	



Scanjet Systems AB
P.O. Box 9316
SE-400 97 Göteborg Sweden
Phone + 46 31 3387530
Fax + 46 31 3387540
E-mail sales@scanjetsystems.com
Web www.scanjetsystems.com